

# NJ 216 ECP

SKF Explorer

## Dimensions

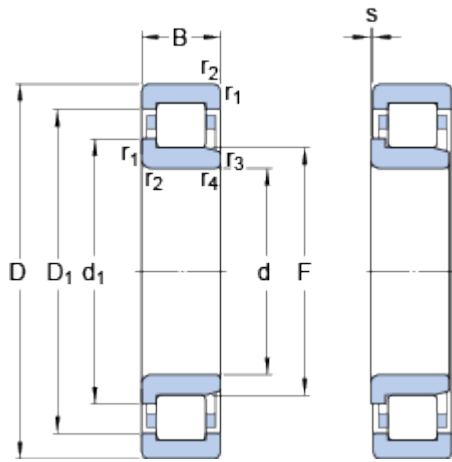

d		80	mm
D		140	mm
B		26	mm
d <sub>1</sub>	≈	101	mm
D <sub>1</sub>	≈	121.7	mm
F		95.3	mm
r <sub>1,2</sub>	min.	2	mm
r <sub>3,4</sub>	min.	2	mm
s		1.4	mm

## Abutment dimensions

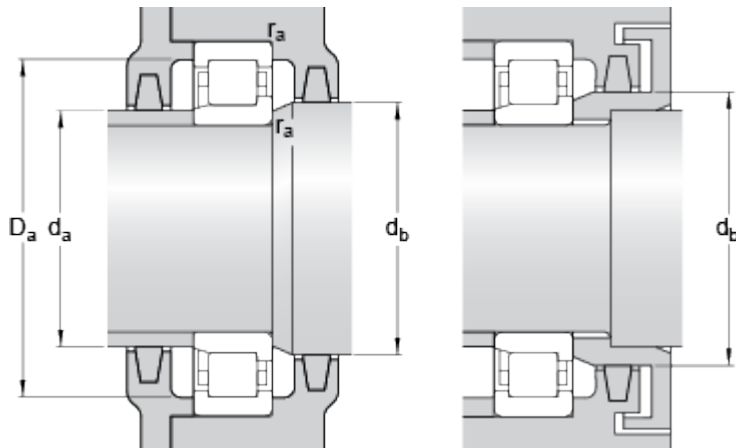

d <sub>a</sub>	min.	90	mm
d <sub>a</sub>	max.	93	mm
d <sub>b</sub>	min.	104	mm
D <sub>a</sub>	max.	129.8	mm
r <sub>a</sub>	max.	2	mm

## Calculation data

Basic dynamic load rating	C	160	kN
Basic static load rating	C <sub>0</sub>	166	kN
Fatigue load limit	P <sub>u</sub>	21.2	kN
Reference speed		5300	r/min
Limiting speed		5600	r/min
Calculation factor	k <sub>r</sub>	0.15	

## Mass

Mass bearing	1.568	kg
--------------	-------	----

## Appropriate products

Angle ring	HJ 216 EC
------------	-----------

